

AC6D35HE

STANDARD MATERIALS AND CONSTRUCTION

FRAME: .081" thk. (nominal) extruded aluminum, 6063-T52/T6 alloy. Channel type.

BLADES: Stationary blades are made from .081" thk. (nominal) extruded aluminum 6063-T52/T6 alloy. Operable blades are made from .032" thk. (nominal) formed aluminum. Blades are approximately 3½" on centers.

LOUVER FACE: Full width sill with head and blades contained within jams.

BEARINGS: Oilite bronze, press fit into frame.

SCREEN: (When indicated, in a removable frame)

½" flattened aluminum, .051" thk.,

-or- 18/6 aluminum mesh insect screen, .011" dia.,

-or- ½" sq. mesh intermediate double crimped aluminum wire, .063" dia.

FINISH: Mill.

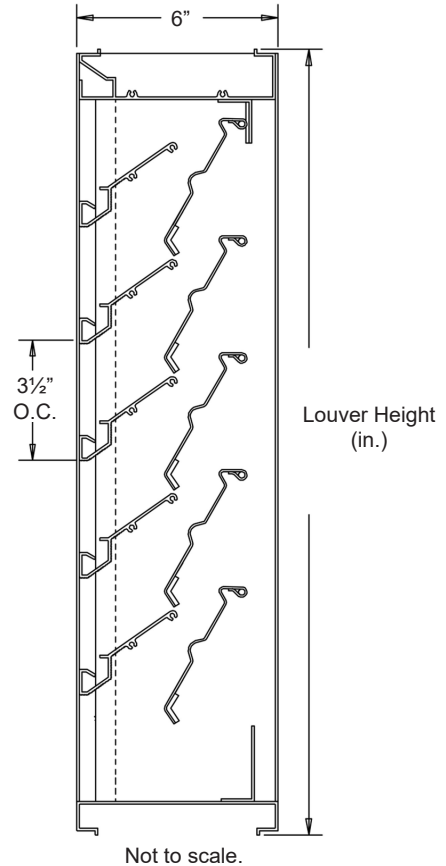

OPTIONS

Finishes - Enamels, Epoxies, etc.

Other screens available.

Actuators - Electric, Pneumatic, Manual, etc.

NOTES

1. Nominal deductions will be made to the opening size given.

2. Approximate shipping weight is 5.3 lbs./sq.ft.

LOUVER SIZES

Min Panel	Max Single Panel
12"W x 12"H	48"W x 72"H

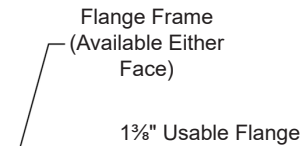

Flange Frame Option

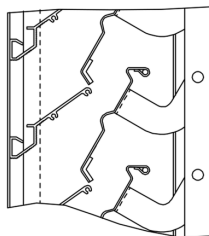

Face Linkage Option

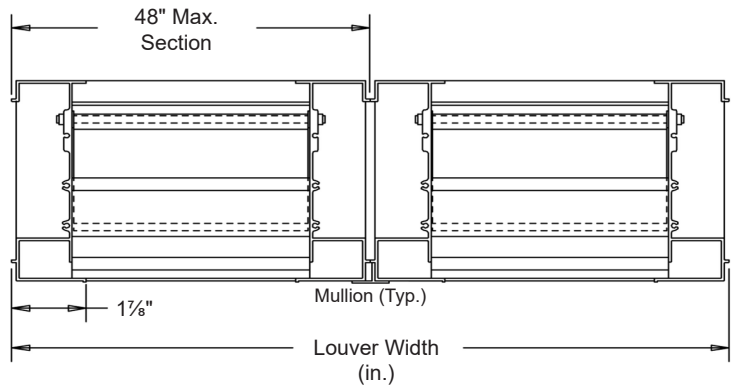

In the interest of product development, Airline Louvers reserves the right to make changes without notice.

										
Item #	Qty	Width	Height	Width	Height	Mullion	Type	Location		
		Opening Size		Louver Size			Screens			Union Made
Arch. / Eng. :						EDR:		ECN:		Job:
Contractor:										
Project:						Date:		DWN:		DWG:

AC6D35HE

PERFORMANCE DATA

Pressure Drop: .19 in. w.g. (exhaust) without Face Linkage
.08 in. w.g. (exhaust) with Face Linkage fully open

Free Area: 8.18 sq.ft. = 51% for 48"W x 48"H sample tested in accordance with AMCA Standard 500-L.

Ratings do not include the effect of a screen.

Without Face Linkage

Louver installed per AMCA Standard 500-L Fig. 5.5
Pressure is corrected to .075 lb./cu.ft. air density.

Operational Pressures
Start to Open - .053 in. w.g.
Open - .182 in. w.g.

With Face Linkage

Louver installed per AMCA Standard 500-L Fig. 5.5 (Face mounted to plenum)
Pressure is corrected to .075 lb./cu.ft. air density.

Operational Pressures
Start to Open - .010 in. w.g.
Open - .073 in. w.g.

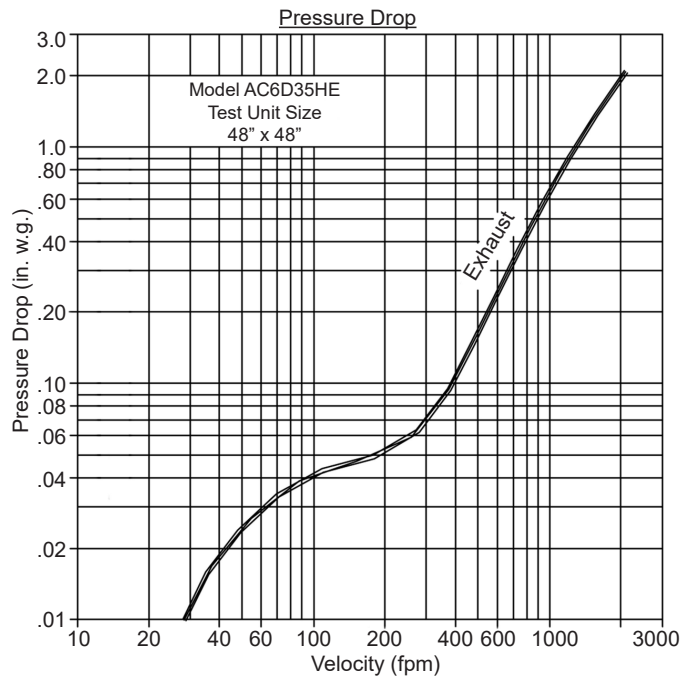
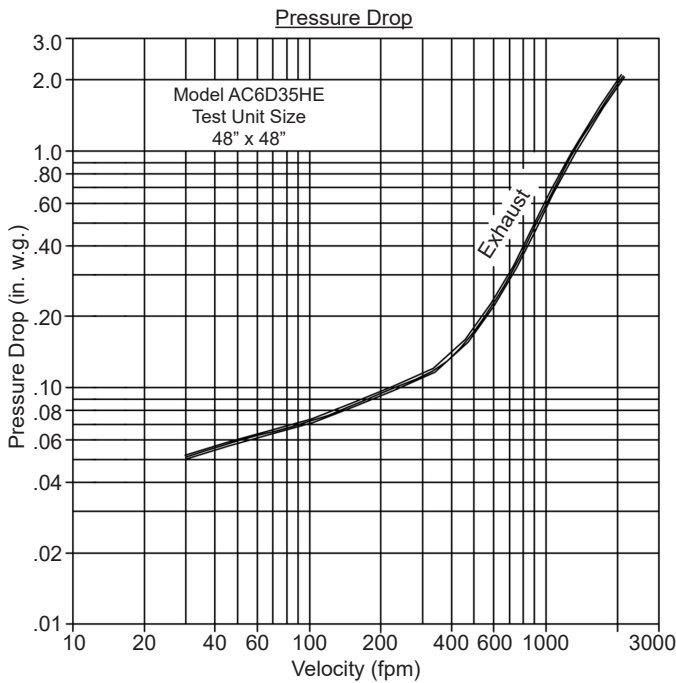

Exhaust air converted to .075 lb./cu.ft. air density.

		Free Area (sq.ft)						
		Width (in.)						
Height (in.)		12"	18"	24"	30"	36"	42"	48"
		12"	.25	.43	.61	.79	.97	1.15
24"	.69	1.20	1.70	2.21	2.71	3.22	3.72	
36"	1.07	1.85	2.63	3.41	4.19	4.97	5.75	
48"	1.52	2.63	3.74	4.85	5.96	7.07	8.18	
60"	1.90	3.28	4.66	6.04	7.42	8.80	10.18	
72"	2.35	4.06	5.77	7.48	9.19	10.90	12.60	

AMCA Registered Laboratory is a laboratory equipped and staged to conduct tests according to the appropriate AMCA test methods and which has been licensed as an AMCA Registered Laboratory.